

## Basic Characteristics Data

Model	Circuit method	Switching frequency [kHz]	Input current *2 [A]	Rated input fuse	Inrush current protection	PCB/Pattern			Series/Parallel operation availability	
						Material	Single sided	Double sided	Series operation	Parallel operation
LEP100F	Active filter	80	1.4	250V 5A	Thermistor	CEM-3	Yes		Yes	*1
	Forward converter	120								
LEP150F	Active filter	80	2.0	250V 6.3A	Thermistor	CEM-3	Yes		Yes	*1
	Forward converter	130								
LEP240F	Active filter	80	3.3	250V 10A	SCR	CEM-3	Yes		Yes	*1
	Forward converter	120								

\*1 Refer to Instruction Manual.

\*2 The value of input current is at ACIN 100V and rated load.

<b>1</b>	<b>Function</b>	<b>E-12</b>
1.1	Input voltage range .....	E-12
1.2	Inrush current limiting .....	E-12
1.3	Overcurrent protection .....	E-12
1.4	Peakcurrent protection .....	E-12
1.5	Overvoltage protection .....	E-12
1.6	Output voltage adjustment range .....	E-12
1.7	Isolation .....	E-12
<b>2</b>	<b>Series Operation and Parallel Operation</b>	<b>E-13</b>
<b>3</b>	<b>Assembling and Installation Method</b>	<b>E-13</b>
3.1	Installation method .....	E-13
3.2	Derating .....	E-13
3.3	Mounting screw .....	E-14
<b>4</b>	<b>Ground</b>	<b>E-15</b>
<b>5</b>	<b>Peak loading</b>	<b>E-15</b>
<b>6</b>	<b>Option and others</b>	<b>E-15</b>
6.1	Outline of option .....	E-15
6.2	Others .....	E-16

# 1 Function

## 1.1 Input voltage range

- The range is from 85 VAC to 264 VAC or 120 VDC to 370 VDC.  
Only AC input is available to comply with agency approval.
- AC input voltage must have a range from 85 VAC to 264 VAC for normal operation. If the wrong input is applied, the unit will not operate properly and/or may be damaged.  
In addition, it is possible to correspond Low input voltage or Instantaneous line drop (optional : -U). Consult with us.

## 1.2 Inrush current limiting

- Inrush current limiting is built-in.
- If a switch is being used for input, ensure that it is configured to handle the input inrush current.

LEP

### ● LEP100F · LEP150F

- The thermistor is used for protection from inrush current. When power is turned ON/OFF repeatedly within a short period of time, it is necessary to have enough time for power supply to cool down.

### ● LEP240F

- A thyristor is used for protection from inrush current. When turning the power OFF and then ON again within a short period of time, inrush current limiting may be disabled; therefore ensure enough time before switching ON.

## 1.3 Overcurrent protection

- Overcurrent protection is built-in and comes into effect at over 101% of the peak current in. Overcurrent protection prevents the unit from short circuit and overcurrent condition.  
The unit automatically recovers when the fault condition is cleared.

### ● Intermittent current characteristics

- When the output voltage drops more than 50% of the rated output voltage value at overcurrent, the average output current is reduced by intermittent operation of power supply.

## 1.4 Peakcurrent protection

- Peakcurrent protection is built-in (refer to Instruction Manual 5. for Peak loading).  
If this function comes into effect, the output is shut down.  
The minimum interval of AC recycling for recovery is 2 to 3 minutes (★).  
★ The recovery time varies depending on input voltage and load condition.

## 1.5 Overvoltage protection

- Output  
Working overvoltage protection.  
Overvoltage protection is built-in and comes into effect at 115-140% of the rated voltage.  
The AC input should be shut down if overvoltage protection is in operation.  
The minimum interval of AC recycling for recovery is 2 to 3 minutes (★).  
★ The recovery time varies depending on input voltage.

### Remarks:

Please avoid applying the over-rated voltage to the output terminal. Power supply may operate incorrectly or fail. In case of operating a motor etc. , please install an external diode on the output terminal to protect the unit.

## 1.6 Output voltage adjustment range

- Adjustment of output voltage is possible by using potentiometer.
- Output voltage is increased by turning potentiometer clockwise and is decreased by turning potentiometer counterclockwise.

## 1.7 Isolation

- For a receiving inspection, such as Hi-Pot test gradually increase (decrease) the voltage for the start (shut down).  
Avoid using Hi-Pot tester with the timer because it may generate voltage a few times higher than the applied voltage, at ON/OFF of a timer.  
If the unit is tested on the isolation between input & output and output & FG, remote ON/OFF (option) must be shorted to outputs.

## 2 Series Operation and Parallel Operation

■ Series operation is available by connecting the outputs of two or more power supplies with the same output voltage, as shown below. Output current in series connection should be lower than the lowest rated current in each unit.

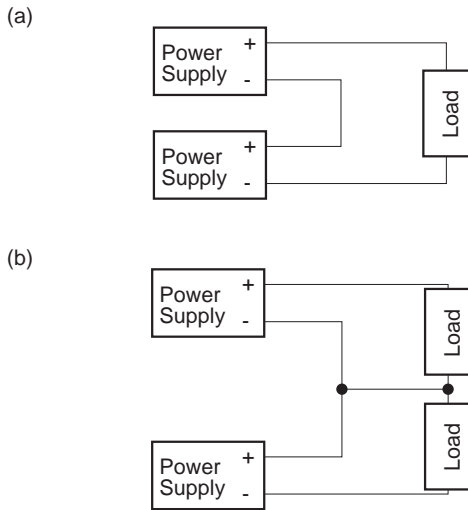

■ Parallel redundancy operation is available by connecting the units as shown below.

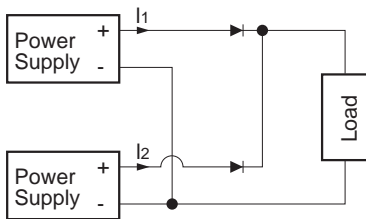

■ Values of  $I_1$  and  $I_2$  become unbalanced by a slight difference of the output voltage. Make sure that the output voltage of units is of equal value and the output current from each power supply does not exceed the rated current.

$$I_1, I_2 \leq \text{the rated current value}$$

## 3 Assembling and Installation Method

### 3.1 Installation method

■ When two or more power supplies are used side by side, position them with proper intervals to allow enough air ventilation. Ambient temperature around each power supply should not exceed the temperature range shown in derating curve.

■ If using a metal chassis, ensure a gap of  $d1$  and  $d2$  between the parts lead and the metal chassis for insulation. If the gap is smaller than  $d1$  and  $d2$ , then ensure that insulation sheet is used between the power supply and the chassis in order to ensure insulation.

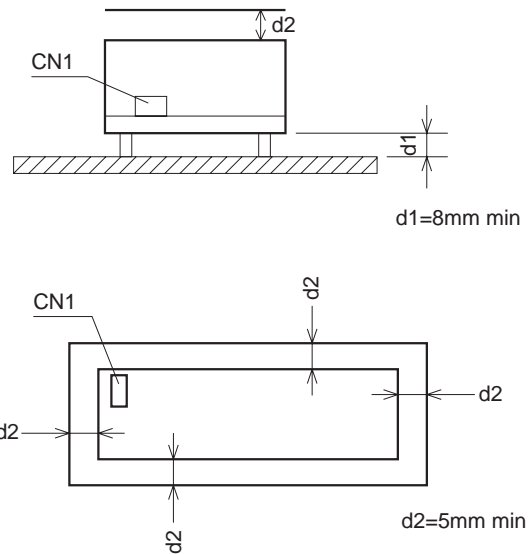

LEP

### 3.2 Derating

■ In the hatched area the specification of Ripple, Ripple Noise is different from other area.

■ In case②, ventilation must keep the temperature of C119 below 85°C. See External View for the location of C119.

■ The operative ambient temperature is different by with/without case cover or mounting position.

Please refer to drawings as below.

#### ● LEP100F

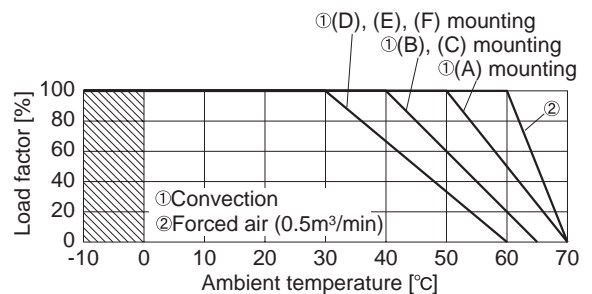

●LEP100F-□-SN (requirement: Min. 90 VAC)

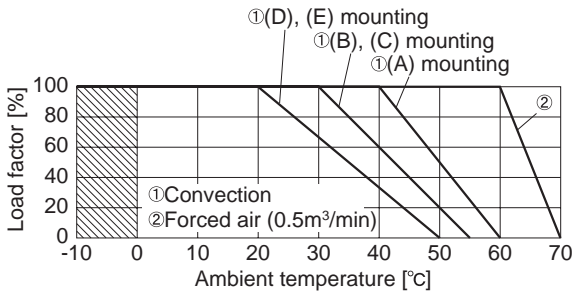

●LEP150F

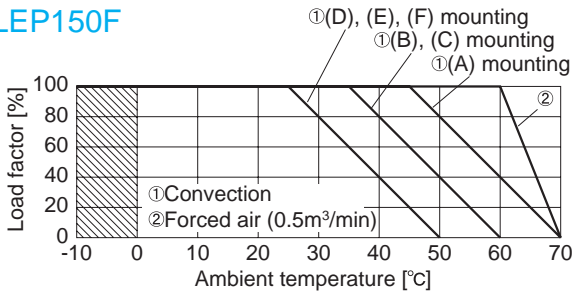

●LEP150F-□-SN (requirement: Min. 90 VAC)

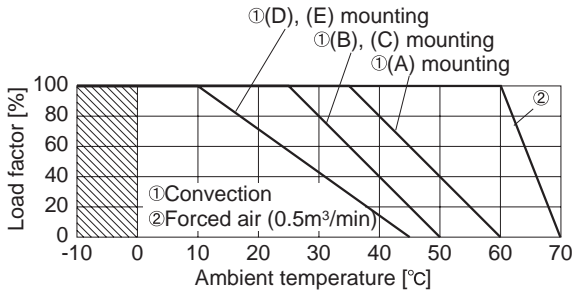

●LEP240F

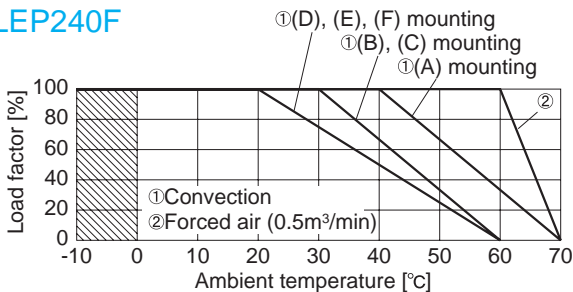

●LEP240F-□-SN (requirement: Min. 90 VAC)

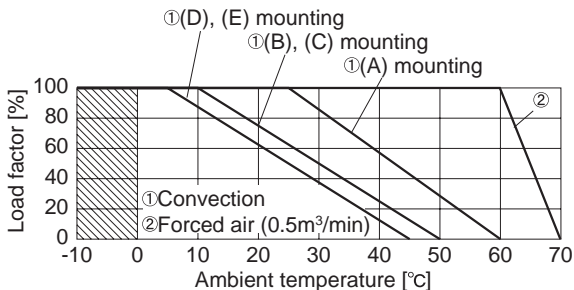

■Use an input voltage of 90 VAC or more when using SN (with chassis cover). This has impaired convection; therefore usage of forced air cooling is recommended.

■When unit mounted except below drawings, it is required to consider ventilated environment by forced air cooling for temperature / load derating. For details, please consult our sales or engineering departments.

■(F) mounting is not possible when a case cover is used. If such mounting can not be avoided, then either forced air cooling to prevent buildup of heat, or temperature and load derating are necessary. For more details, please consult our engineering department.

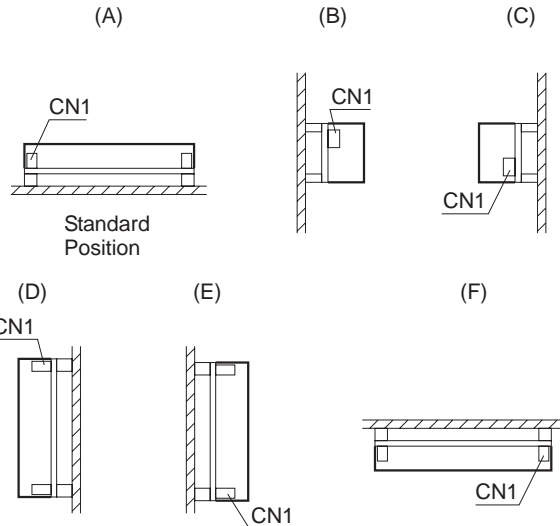

### 3.3 Mounting screw

■The mounting screw should be M3. The hatched area shows the allowance of metal parts for mounting.

■If metallic fittings are used on the component side of the board, ensure there is no contact with surface mounted components.

■Keep isolation distance between screw and internal components in case of option "-S", "-SN" as below chart.

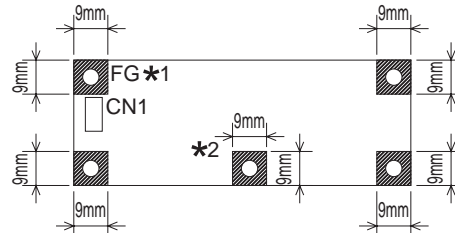

\*1 Recommendation to electrically connect FG to metal chassis for reducing noise.

\*2 LEP150F and LEP240F only  
Refer to External view for location

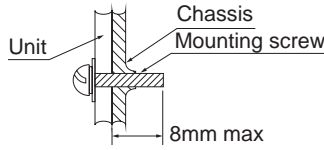

## 4 Ground

■When installing the power supply with your unit, ensure that the input FG terminal of CN1 or mounting hole FG is connected to safety ground of the unit.

However when applying the safety agency, connect the input FG terminal of CN1 to safety ground of the unit.

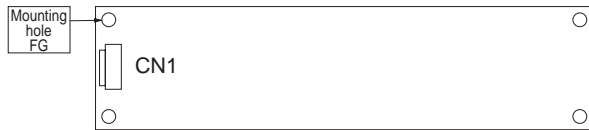

## 5 Peak loading

■Peak load is possible to draw as below.

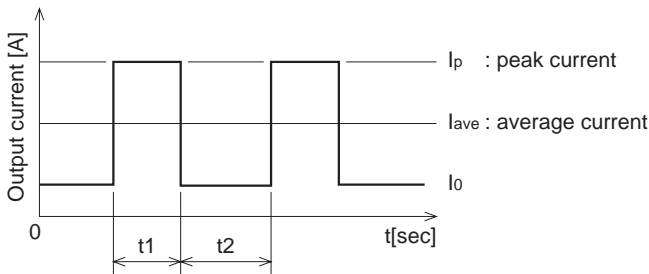

$$t1 \leq 10 [\text{sec}], I_{ave} = \frac{I_p t1 + I_o t2}{t1 + t2} \leq \text{rated current},$$

$$\frac{t1}{t1 + t2} \leq 0.35 \text{ (at LEP100F)}$$

$$\frac{t1}{t1 + t2} \leq \text{Duty (at LEP150F, LEP240F)}$$

In case of LEP150F, LEP240F, Duty is depended on peak load, refer to below chart.

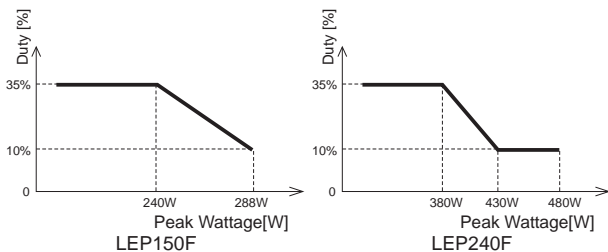

## 6 Option and others

### 6.1 Outline of option

#### ●-G

■Option "-G" means leakage current is smaller than standard model by reducing the value of earth capacitor at input filter circuit.

Leakage current	0.1mA max
Conducted noise	Not available

#### ●-R

■Option "-R" is available for remote ON/OFF.

Between RC(+) and RC(-)	Output
SW ON (4.5 - 12.5V)	ON
SW OFF (0 - 0.5V)	OFF

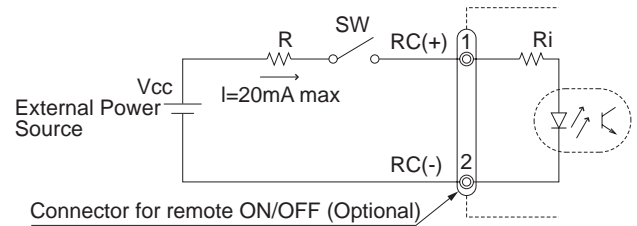

■When external power source is in the range of 4.5 - 12.5V, current limit resistance R is not required. However, when external power source exceeds 12.5V, current limit resistance R must be connected.

To calculate the current limit resistance, use the following equation:

$$R[\Omega] = \frac{V_{cc} - (1.1 + R_i \times 0.005)}{0.005}$$

Where;

V<sub>cc</sub> = External Power Source

R<sub>i</sub> = The internal resistance (780Ω)

■A wrong connection may damage the internal components of the unit.

■Remote ON/OFF circuit (RC(+), RC(-)) is isolated from input, output and FG.

●-S · -SN

■-S indicates a type with chassis, and -SN indicates a type with chassis and cover. (Refer external diagram) Refer to "Derating Curves" in Section 3.2.

●-T

■Option "-T" means input and output interface are changed "Connector" to "Terminal block".



●-U

• Specifications for support of instantaneous voltage dips (low input voltage support).

Use condition

Input	AC50V(DC70V)
	Duty 1s/30s
Output	LEP100F 75W
	LEP150F 114W
	LEP240F 180W

★Avoid continuous use at low input voltage for more than 1 second, as such use can lead to damage to the power supply.

●-Z □

■Our ZT3 series product can be equipped as an option. Refer to the external diagram for the output interface. Refer to the full catalog for ZT specifications. ZT can be selected from the following.

Optional symbol	-Z31	-Z32	-Z33	-Z34	-Z35
Mounted Power supply	ZTS3	ZTS3	ZTS3	ZTW3	ZTW3
	2405	2412	2415	2412	2415
Notice	Output voltage in LEP series is 24[V], 36[V].				
Optional symbol	-Z41	-Z42	-Z43	-Z44	-Z45
Mounted Power supply	ZTS3	ZTS3	ZTS3	ZTW3	ZTW3
	4805	4812	4815	4812	4815
Notice	Output voltage in LEP series is 48[V].				

6.2 Others

- This power supply is the rugged PCB type. Do not drop conductive objects in the power supply.
- At light load, there remains high voltage inside the power supply for a few minutes after power OFF.  
So, at maintenance, take care about electric shock.
- This power supply is manufactured by SMD technology. The stress to PCB like twisting or bending causes the defect of the unit, so handle the unit with care.